



Industrial Filters · Accumulators

VacuClean[®]

Systematic Oil Treatment
Patented



All-In-One system for cleaning and reconditioning of hydraulic oils and lubricants in the bypass flow

Separation of water and other liquid contaminants

Removal of air and other gases

Compact and easy to move design

Size

*Mobile: 15, 30, 60l/min
Stationary: up to 300 l/min*



Quality assured!

VacuClean®

Special features

PLC controlled operation

Self monitoring, automatic shut down in case of malfunction

Plain text display for operating instructions and trouble shooting

Adjustable flow rate from 5 l/min up to nominal flow

Integrated data logger for a complete documentation over the whole running time

High flexibility due to compact and easy-to-clean design

Extremely fast separation due to high efficiency in one single pass

Low maintenance, uncomplicated operation

No cooling water consumption due to new principle and totally oil free and dry waste air

Multiple enhancement of fluid life

Enormous reduction of corrosion

Multiple enhancement of component life

Integrated bypass flow filtration system for separation of solid particles down to 1 µm

Special high efficiency glassfiber filter media

Filter elements in ECO-Pore® design, thereby reducing operating costs

High separation efficiency down to 50 ppm

Oil viscosity: 5- 640 cSt (with optional heating module)

Online measurement of water content

Options

Special designed heating module for gentle oil warm up with high efficiency through use of waste heat

Regenerable air drying unit when the surrounding air is too humid

Power data

Test medium: hydraulic oil ISO VG 46

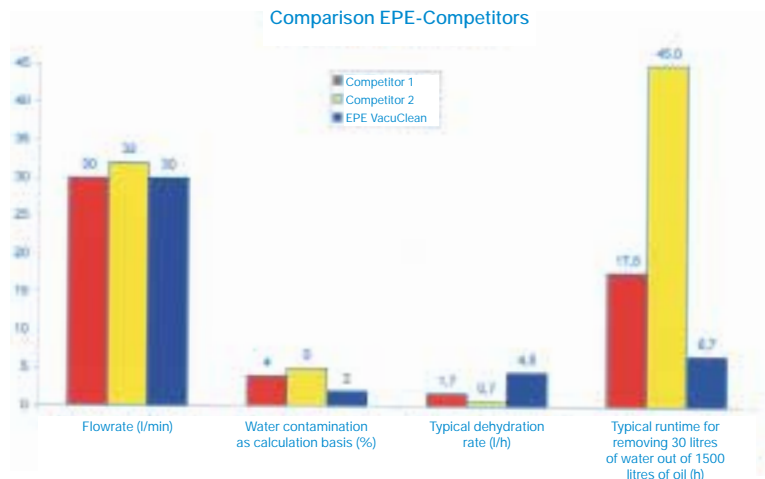
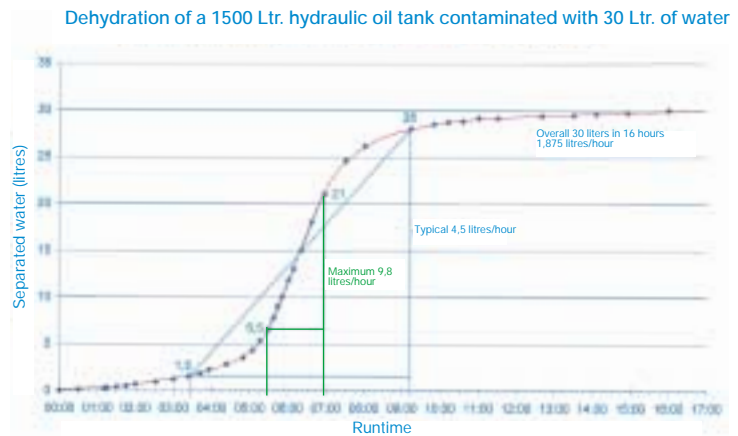
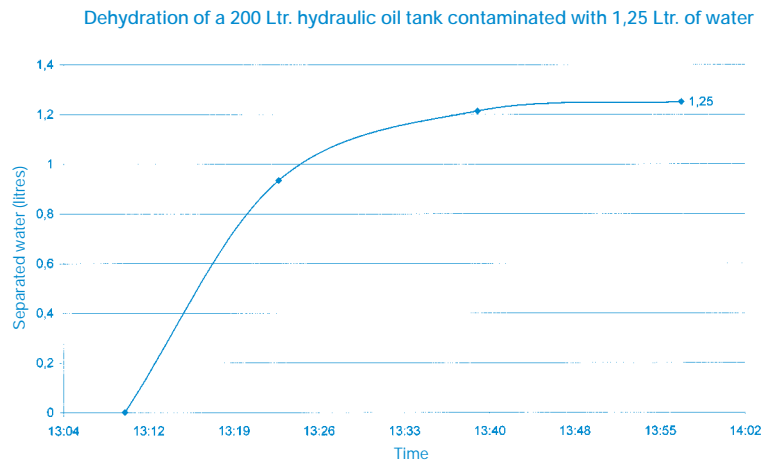

Why VacuClean®?

In times of increasing demands concerning service time and reliability of modern hydraulic and lubrication systems, the used fluid gets more and more important. Studies show that already 80% of all unplanned machine downtimes can be traced back to the fluid.

It is therefore necessary, not only to control the fluid regularly but also to keep it in its best possible condition by predictive maintenance.

The worsening of the fluids characteristics is caused by four major reasons:

1. solid contamination
2. water intake
3. air and gas intake
4. fluid oxidation

The solid contamination can be controlled pretty easily using appropriate bypass filters.

Hereby very high oil cleanliness codes are achieved and kept for a long period of time preventing machines from initial failures.

The contamination by water intake is much more problematic, because it is hard to avoid at any time.

Water can get in the system through:

- condensation of air humidity
- injected water, e.g. by use of high pressurized cleaners
- cooler failures or similar problems
- rain
- oil refilling

Impact of water in the system:

1. water deposits preferentially in fine cracks on bearings and sliding surfaces causing corrosion and similar effects.
2. Especially in combination with metal particles having a catalytic effect, water accelerates the oxidation very fast. This was already examined very detailed.
3. Further examinations show that already a water concentration of 500 ppm (0,05%) affects considerably the lifetime of a rolling bearing. In the reverse case the lifetime of the bearing can be extended several times by consistently keeping the water concentration down at 50 ppm (0,005 %).

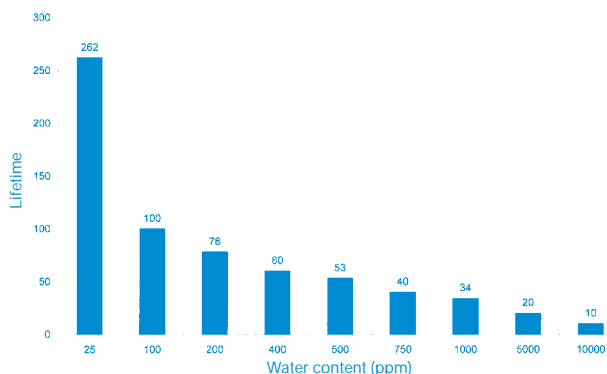

4. Water increases the TAN (total acid number) up to 4 to 10 times and thereby accelerates the fluid's decomposition. This also happens in an intensified dimension if catalytic metal particles are present.
5. In dissolved and emulsified form the fluid's viscosity and with it its lubrication ability will be changed. This leads to enhanced friction and with it to extensive heat development.

6. Dissolved water attracts dust due to its dielectric strength, leading to the contamination of the fluid and to the formation of dust agglomerates which can for example clog servo valves. Due to the low particle size of single dust particles they can hardly be removed by filtration.
7. Additives which can be polarized are removed from the fluid worsening further the fluid's characteristics.
8. Water supports the development of silt.
9. Water worsens the filterability of the fluid by blocking the filter elements on their surface.

Air and gas gets into the system through:

- leakage at the suction side of pumps
- the return line to the reservoir
- open lubrication locations
- low filling levels
- strong turbulences in the reservoir

Impact of air:

1. Air causes cavitation in pumps. This surely will lead to their failure.
2. Through compressibility of the air bubbles the behaviour of valves and technical controls is interfered.
3. Acceleration of the fluid oxidation.
4. Especially in combination with catalytic metal particles a decomposition of the fluid will occur. Hereby organic acids, Aldehydes, Ketones and Peroxides will be formed. This leads to:
 - further decomposition of the fluid
 - increasement of the total acid number (TAN)
 - Peroxides trigger radicalic polymerisations leading to high moleculars, grease, mud or tar and similar substances. They can for example clog valves or block filters.

The treatment of oil using VacuClean® ensures:

- Reduction of unplanned machine downtimes
- Reduction of cavitation, thereby
- Extension of pump lifetime
- Extension of lubricated parts lifetime
- Reduction of oil oxidation and decomposition, thereby
- Extension of maintenance periods of the used fluid, thereby
- Reducing the costs for fresh oil and
- Reducing the disposal costs
- Reducing the operating costs, due to less downtimes needed for oil change

Online measurement of water content

The new principle uses a polymer thin film sensor which supplies very precise test data in almost real time mode.

The long waiting period when analyzing the water concentration in compliance to the Karl Fischer method in a laboratory is no longer necessary. The subject of the measurement is the water activity in the fluid. This means that only the content of dissolved or bonded water will be detected.

Free water can not be measured with this method. However the instrument indicates the presence of free water. In any case free water will cause severe damage and has to be removed completely.

Basic VacuClean® Scheme

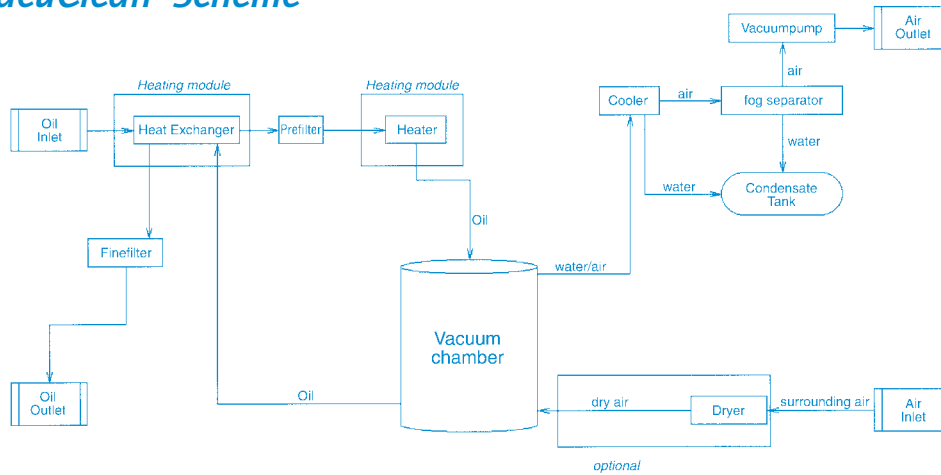

Ordering Code

Type	Magnet	Maintenance Indicator	Connection	Material	Heater	Online Water Measurement						
VCM= VacuClean® mobile VCS= VacuClean® stationary	O= without	O= without D= optical/electrical with three 24V diodes and two switch points Switching pressure: 2,5 bar	00= standard	O= standard	O= without F= 36kW G= 27kW H= 24kW I= 12kW	O= without 1= upstream 2= upstream+downstream						
Complete Unit → 30	VCM	0145C	H3SL - 0	00 - 0	0	D2,5 - 00	V	0	0	I	D	0
Seal Kit → D30	VCM	0145C	-	-	-	D - 00	V	0	-	-	-	-
Size	Filter size	Filtration Grade	Diff. Pressure	Element Model	Bypass Valve	Seal	Data Logger	Sight glass				
15 30 60 90* 150* 300* <small>*stationary only</small>	0145C 0200C 0270C	Absolute filter fineness (ISO 4572) in µm H..SL= Microglas not cleanable Mainfilter H1SL, H3SL, H6SL, H10SL Prefilter H10SL, H20SL	O= standard	O..= standard adhesive T= 100°C ..O= standard material	O= without	V= Viton E= Ethylene-propylene N= Neoprene	O= no D= yes	O= 4 pieces S= 10 pieces				
Filter Element 1.	C= Ecopore®											
Main Filter Element 1.	0145C	H3SL - 0	00 - 0	-	0	-	V					
Pre Filter Element 1.	0145C	H10SL - 0	00 - 0	-	0	-	V					

Spare Parts List

- Filter element for main filter: 1.0145C H3SL-0 00-0-V 3µm absolute filtration grade also in H1SL,H6SL, H10SL
- Filter element for pre filter: 1.0145C H10SL-0 00-0-V H10SL in combination with main filter element H1SL or H3SL
- Filter element for breather filter: 7.004 G10-S 0V-0-V H20SL in combination with main filter element H6SL or H10SL
- Sealing kit: refer to ordering information above
- Filter housing for pre and main filter: refer to data sheet 40C for filter 40FLE 0145C H...SL-000-00F2,5-SOVDDBE
- Breather filter: refer to data sheet 10 for filter TLF5-65 G10-S0V-000-00PVO

Dimensions

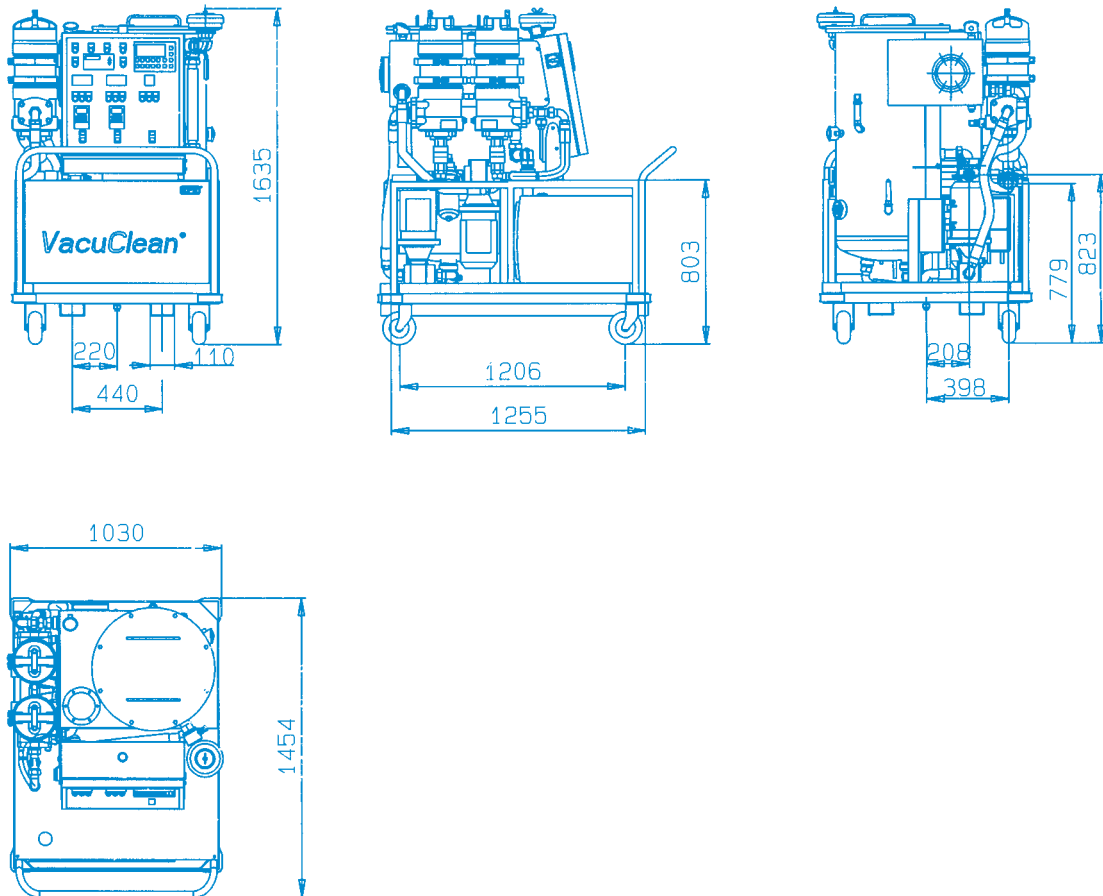

The Heating Module

Consists of a heat exchanger, an electrical heater and an oil cooler. In all locations where the temperature of the oil is below 50°C, a heating module has to be used. Because of the VacuClean® system reaching its maximum dehydration rate at 60°C, it is generally recommended to use the heating module.

In order not to harm the oil (oxidation, cracking, etc.) a very low specific heating area load has to be observed. The main oil manufacturers allow up to 2,4 W/cm². However the heater was designed in a manner that the maximum specific heating load is only 1 W/cm², thereby absolutely ruling out any negative effect on the oil. In the heat exchanger the cold oil flows towards the treated warm oil thus being preheated. The necessary heat influx in the electric heater thereby is reduced and the energy efficiency is improved.

Quality and Standardisation

The development, manufacture and assembly of EPE-Industrial filters and filter elements is carried out within the framework of a certified quality-management-system in accordance with DIN EN ISO 9001. The stability calculation and testing of the filters proceeds according to existing pressure vessel regulations, as well as in accordance with national and international norms. Certification of the filters by accredited institutions (for example TÜV, GL, LRS, LRIS, ABS, BV, DNV, DRIRE, UDT etc.) is available on request.



Industrial Filters · Accumulators

Installation, Starting, Maintenance

The Initial installation as well as the first starting and the adjustment to the optimum parameters is done by an EPE technician. Afterwards the One-Button-Operation makes sure that there is no operator error. When moving to another tank (only mobile system VCM) only the Stop-Button has to be pressed. When switching off the main switch, even the solenoid valves at the inlet and outlet are closed, so that there can be no leakage of oil during transportation. To start the VacuClean® again only the Start-Button has to be pressed.

Filter Element Service

Shut down the VacuClean® system. Open the breather filter slowly to remove the vacuum in the main chamber. Empty the filter housing by opening the draining screw. Unscrew filter head. Carefully turn the filter elements and pull it upwards to remove it from the central core.

Attention! The filters are equipped with ECOPore® elements. This means, the core is to be reused! It stays in the filter housing. Only the filter material is to be disposed!

Moisten the o-rings of the new filter element with a small amount of oil. Carefully push the new element over the central core to the stop and fix it with a slight turn. The upper o-ring now has to seal on the upper ring of the central core.

Check the o-ring in the filter head and replace it when necessary. Carefully screw the filter head. Hand-tightening is enough to ensure the tightness. The VacuClean® can now be started again.

Technical data of 30 VCM

Connection to fluid:	The ends of the supplied hoses are to be inserted in the tank at two points (min. Ø 60 mm). The distance between them should be as far as possible. Special connections on demand are possible.
Power Supply:	380 V, 50 Hz, 16 A CEE plug Other power connections on demand are possible.
Power Input:	8 KW
Oil flow:	5-50 l/min adjustable
Dehydration rate:	maximum: 9,8 l/h typical: 4,5 l/h
Remaining water content:	< 50 ppm (typical: 40 ppm)

Technical data heating module

Connection to main system:	The module is connected by four supplied hoses and a control line.
Electrical Connection:	380 V, 50 Hz, 63 A CEE plug / (36 KW) Other power connections on demand are possible.
Total power input:	37 KW (28 KW, 25 KW, 12 KW)
Final temperature:	50-80°C adjustable
Heating surface loading:	1 W/cm ²
Size:	800 x 1500 x 1200 mm (BxHxT)

Warning

Connect and disconnect system only when power is switched off!
Vessel is under vacuum!
Do not change filter element when system is switched on!
Functions and safety warranty only with EPE-spare part!
Service filter only by trained person!!

Technical specification are subject to change!

95A-GB/01/10.01/2.000/Wei

中国区总代理：
奥米尔工业有限公司
地址：
上海市商城路738号胜康廖氏大厦2409室
电话：021-58355625 58355623
传真：021-58355630
[http:// www.aomiao.com](http://www.aomiao.com)